

2011

PART 01 — ENGINEERING MATHEMATICS

(Common to all candidates)
(Answer ALL questions)

1. If the rank of a matrix $\begin{pmatrix} 1 & 1 & -1 & 0 \\ 4 & 4 & -3 & 1 \\ b & 2 & 2 & 2 \\ 9 & 9 & b & 3 \end{pmatrix}$ is 3, then

value of b is

- 1) 3 2) 1 3) -6 4) 4
2. If the rank of non-square matrix A and rank of the augmented matrix of system of linear equations are equal, then the system
- 1) is inconsistent 2) has no solution
3) is consistent 4) does not have solution
3. If the system $-2x+y+z=a$, $x-2y+z=b$, $x+y-2z=c$, where a, b, c are constants, is consistent, then it has infinite solutions only when
- 1) $a+b+c=0$ 2) $a-b+c=0$
3) $a+b-c=0$ 4) $a+b+c \neq 0$

4. If $A = \begin{pmatrix} 1 & 2 & 2 \\ 0 & 2 & 1 \\ -1 & 2 & 2 \end{pmatrix}$, then the algebraic and geometric multiplicity are respectively
- 1) 2, 2 2) 1, 2 3) 1, 1 4) 2, 1

5. The signature of quadratic form $2xy+2yz+2zx$ is
- 1) 3 2) -1 3) 2 4) 1

6. If $u = \log\left(\frac{x^2}{y}\right)$, then $xu_x + yu_y$ is equal to
- 1) 2u 2) u 3) 0 4) 1

7. If $u = \tan^{-1}\left(\frac{x^3 + y^3}{x - y}\right)$, then $x^2u_{xx} + 2xyu_{xy} + y^2u_{yy}$ equals
- 1) 0 2) $\sin u \cos 3u$
3) $\sin 3u \cos u$ 4) $2\sin u \cos 3u$

8. If $u = xyz$, $v = x^2 + y^2 + z^2$, $w = x + y + z$, then $\frac{\partial(x, y, z)}{\partial(u, v, w)}$ is equal to
- 1) $-2(x-y)(y-z)(z-x)$ 2) $(x-y)(y-z)(z-x)$
3) $\frac{1}{2(x-y)(y-z)(z-x)}$ 4) xyz

9. The particular integral of $(D^2+D)y=x^2+2x+4$ is

- 1) x^2+4 2) $\frac{x^3}{3} + 2x$
3) $\frac{x^3+12x}{3}$ 4) $\frac{1}{3}(x^3+4x)$

10. In the equation $x'(t) + 2y(t) = -\sin t$, $y'(t) - 2x(t) = \cos t$, given $x(0) = 0$ and $y(0) = 1$, if $x = \cos 2t - \sin 2t - \cos t$, then y is equal to

- 1) $\cos 2t - \sin 2t + \sin t$ 2) $\cos 2t + \sin 2t - \sin t$
3) $\sin 2t - \cos 2t - \sin t$ 4) $\cos 2t + \sin 2t + \sin t$

11. If minimum value of $f(x) = x^2 + 2bx + 2c^2$ is greater than maximum value of $g(x) = -x^2 - 2cx + b^2$, then for x is real,

- 1) $0 < c < \sqrt{2b}$ 2) no real value of a
3) $|c| > \sqrt{2}|b|$ 4) $\sqrt{2}|c| > b$

12. Form the partial differential equation by eliminating the arbitrary constants a and b from

$$z = a \log \left\{ \frac{b(y-1)}{1-x} \right\} \text{ as}$$

- 1) $xp = yq$ 2) $p+q = xp+yq$
3) $yp = xq$ 4) $p+q = z$

13. The particular integral of $(2D^2 - 3DD' + D^2)z = e^{x+2y}$ is

- 1) $\frac{1}{2}e^{x+2y}$ 2) $-\frac{x}{2}e^{x+2y}$ 3) xe^{x+2y} 4) $\frac{x^2}{2}e^{x+2y}$

14. If $f = \tan^{-1}\left(\frac{y}{x}\right)$, then $\text{div}(\text{grad } f)$ is equal to

- 1) -1 2) 1 3) 2 4) 0

15. If $\vec{F} = ax\vec{i} + by\vec{j} + cz\vec{k}$, then $\iint_S \vec{F} \cdot d\vec{S}$, where S is the surface of a unit sphere, is

- 1) $\frac{4\pi}{3(a+b+c)}$ 2) $\frac{4}{3}\pi(a+b+c)^2$
3) $\frac{4\pi}{3}(a+b+c)$ 4) 0

16. The value of $\int_C [(y - \sin x) dx + \cos y dy]$, where C is the plane triangle enclosed by the lines $y=0$, $y = \frac{\pi}{2}$ and $y = \frac{2}{\pi} x$, is
 1) $\frac{8}{\pi}$ 2) $-\frac{1}{4\pi}(\pi^2+8)$ 3) $\frac{1}{8\pi}(\pi^2+4)$ 4) π^2+2
17. If $f(z)=u+iv$ is analytic, then its first derivative equals
 1) $\frac{\partial u}{\partial x} - i \frac{\partial v}{\partial x}$ 2) $\frac{\partial u}{\partial x} + i \frac{\partial v}{\partial y}$ 3) $\frac{\partial v}{\partial y} - i \frac{\partial u}{\partial x}$ 4) $\frac{\partial u}{\partial x} - i \frac{\partial u}{\partial y}$
18. The value of $\int_C \frac{3z+4}{2z+1} dz$, where C is the circle $|z|=1$, is
 1) πi 2) $3\pi i$ 3) $2\pi i$ 4) $\frac{\pi}{3}$
19. The value of $\int_C \frac{4z^2+z+5}{z-4} dz$, where C is the ellipse $\left(\frac{3x}{2}\right)^2 + y^2 = 32$, is
 1) 3 2) 0 3) $\frac{2}{3}$ 4) -1
20. The pole of $\frac{1}{\cos z - \sin z}$ is
 1) $\frac{\pi}{2}$ 2) $\frac{\pi}{3}$ 3) π 4) $\frac{\pi}{4}$
21. The value of $\int_0^{\infty} \frac{1}{t} (e^{-t} \sin^2 t) dt$ is
 1) $\frac{1}{5} \log 2$ 2) $\frac{1}{4} \log 5$ 3) $\log 3$ 4) 0
22. The solution of $(D^2+9)y = \cos 2t$, $y(0)=1$ and $y(\pi/2)=1$ is given by
 1) $y = \frac{1}{5} (\cos 3t + 4 \sin 3t + 4 \cos 2t)$
 2) $y = \frac{1}{5} (2 \cos 2t + \sin 3t + \cos 3t)$
 3) $y = \frac{1}{5} (\cos 2t + 4 \sin 3t + 4 \cos 3t)$
 4) $y = \frac{-1}{5} (\cos 2t - 4 \sin 3t + 4 \cos 3t)$

23. The Fourier sine transform of $e^{-\frac{ax}{x}}$ is
 1) $\tan^{-1}(s/a)$ 2) $\tan^{-1}(s/2a)$
 3) $\tanh^{-1}(s/a)$ 4) $\frac{1}{2} \tan^{-1}(s/a)$
24. If $Z(u_n) = \frac{2z^2 + 3z + 4}{(z-3)^3}$, $|z| > 3$, then the value of u_3 is equal to
 1) 21 2) 193 3) 46 4) 139
25. As soon as a new value of a variable is found, it is used immediately in the equations, such method is known as
 1) Gauss-Jordan method
 2) Gauss-Jacobi's method
 3) Gauss Elimination method
 4) Gauss-Seidel method
26. The value of x for the data (0, 1), (1, 3), (2, 9), (3, x) and (4, 81) is
 1) 31 2) 18 3) 27 4) 36
27. If $y(0)=2$, $y(1)=4$, $y(2)=8$ and $y(4)=32$, then $y(3)$ is equal to
 1) 12 2) 16.5 3) 18 4) 20
28. The joint probability density function of a random variable (x, y) is given by $f(x, y) = kxye^{-(x^2+y^2)}$, where $x, y > 0$. Then the value of k is
 1) 1 2) 3 3) 4 4) 2
29. The two lines of regression are perpendicular to each other if the co-efficient of correlation equals
 1) 0 2) 1 3) -1 4) ± 1
30. Let the random variable X have the probability density function

$$f(x) = \begin{cases} xe^{-x} & \text{for } x > 0 \\ 0 & \text{otherwise} \end{cases}$$
 Then the moment generating function is
 1) $\frac{1}{1-2t}$ 2) $\frac{1}{1-t}$ 3) $\frac{1}{1+t}$ 4) $\frac{2}{2-t}$

ME - ENGINEERING MATHS : ANSWERS

1 3	2 3	3 1	4 1	5 2	6 4	7 4	8 3	9 3	10 2
11 3	12 2	13 2	14 4	15 3	16 *	17 4	18 3	19 2	20 4
21 2	22 *	23 1	24 3	25 4	26 3	27 2	28 3	29 1	30 *

PART 01 — ENGINEERING MATHEMATICS
DETAILED SOLUTIONS

1. (3)

$$\begin{bmatrix} 1 & 1 & -1 & 0 \\ 4 & 4 & -3 & 1 \\ b & 2 & 2 & 2 \\ 9 & 9 & b & 3 \end{bmatrix}$$

$$\sim \begin{bmatrix} 1 & 0 & 0 & 0 \\ 4 & 0 & 1 & 1 \\ b & 2-b & 2+b & 2 \\ 9 & 0 & 9+b & 3 \end{bmatrix}$$

$$\sim \begin{bmatrix} 1 & 0 & 0 & 0 \\ 4 & 1 & 1 & 0 \\ b & 2+b & 2 & 2-b \\ 9 & 9+b & 3 & 0 \end{bmatrix}$$

$$\sim \begin{bmatrix} 1 & 0 & 0 & 0 \\ 4 & 1 & 0 & 0 \\ b & 2+b & -b & 2-b \\ 9 & 9+b & -6-b & 0 \end{bmatrix}$$

Since the rank is 3 any determinant of order 4=0

$$\therefore 1 \times \begin{vmatrix} 1 & 0 & 0 \\ 2+b & -b & 2-b \\ 9+b & -6-b & 0 \end{vmatrix} = 0$$

$$\Rightarrow 1(2-b)(6+b) = 0$$

$$\therefore b = -6 \text{ (or) } b = 2$$

2. (3)

If $\rho(A) = \rho(A, B)$ then the given system is consistent.

3. (1)

$$[A, B] = \begin{bmatrix} -2 & 1 & 1 & a \\ 1 & -2 & 1 & b \\ 1 & 1 & -2 & c \end{bmatrix}$$

$$\sim \begin{bmatrix} 1 & -2 & 1 & b \\ -2 & 1 & 1 & a \\ 1 & 1 & -2 & c \end{bmatrix} R_1 \leftrightarrow R_2$$

$$\sim \begin{bmatrix} 1 & -2 & 1 & b \\ 0 & -3 & 3 & a+2b \\ 0 & 3 & -3 & c-b \end{bmatrix}$$

$$\sim \begin{bmatrix} 1 & -2 & 1 & b \\ 0 & -3 & 3 & a+2b \\ 0 & 0 & 0 & a+b+c \end{bmatrix}$$

Since the system has infinite solutions implies rank is less than 3.

$$\therefore a+b+c = 0$$

4. (1)

Algebraic multiplicity = 2

Geometric multiplicity = 2

5. (2)

$$A = \begin{bmatrix} 0 & 1 & 1 \\ 1 & 0 & 1 \\ 1 & 1 & 0 \end{bmatrix}$$

$$|A| = -1[0-1] + 1[1-0]$$

$$= 1+1 = 2$$

$$D_1 = |a_{11}| = 0$$

$$D_2 = \begin{vmatrix} 0 & 1 \\ 1 & 0 \end{vmatrix} = 0-1 = -1$$

$$D_3 = |A| = 2$$

Difference between positive square terms and non positive square terms

$$= 1-2 = -1$$

\therefore Signature = -1

6. (4)

$$u = \log\left(\frac{x^2}{y}\right)$$

$$ux = \frac{\partial u}{\partial x} = \frac{1}{\left(\frac{x^2}{y}\right)} \cdot \frac{2x}{y}$$

$$= \frac{y}{x^2} \cdot \frac{2x}{y} = \frac{2}{x}$$

$$u_y = \frac{\partial u}{\partial y} = \frac{1}{\left(\frac{x^2}{y}\right)} \cdot \left(\frac{-x^2}{y^2}\right)$$

$$= \frac{y}{x^2} \left(\frac{-x^2}{y^2} = \frac{-1}{y}\right)$$

$$\therefore xu_x + yu_y = x\left(\frac{2}{x}\right) + y\left(\frac{-1}{y}\right)$$

$$= 2 - 1 = 1$$

7. (4)

$$\text{Let } f(u) = z = \tan u$$

$$= \frac{x^3 + y^3}{x - y}$$

Clearly z is a homogeneous function of degree 2.

$$g(u) = \frac{nf(u)}{f'(u)}$$

$$= \frac{2 \times \tan u}{\sec^2 u}$$

$$= 2 \times \frac{\sin u}{\cos u} \times \cos^2 u$$

$$= 2 \sin u \cos u$$

$$= \sin 2u$$

Formula :

$$x^2 \frac{\partial^2 u}{\partial x^2} + 2xy \frac{\partial^2 u}{\partial x \partial y} + y^2 \frac{\partial^2 u}{\partial y^2}$$

$$= g(u)[g'(u) - 1]$$

$$= \sin 2u(2 \cos 2u - 1)$$

$$= 2 \sin 2u \cos 2u - \sin^2 2u$$

$$= \sin 4u - \sin^2 2u$$

$$= 2 \sin u \cos 3u$$

8. (3)

$$u = xyz$$

$$\therefore \frac{\partial u}{\partial x} = yz; \frac{\partial u}{\partial y} = xz; \frac{\partial u}{\partial z} = xy$$

$$v = x^2 + y^2 + z^2$$

$$\frac{\partial v}{\partial x} = 2x; \frac{\partial v}{\partial y} = 2y; \frac{\partial v}{\partial z} = 2z$$

$$w = x + y + z$$

$$\frac{\partial w}{\partial x} = 1; \frac{\partial w}{\partial y} = 1; \frac{\partial w}{\partial z} = 1$$

Now

$$\frac{\partial(u, v, w)}{\partial(x, y, z)} = \begin{vmatrix} \frac{\partial u}{\partial x} & \frac{\partial u}{\partial y} & \frac{\partial u}{\partial z} \\ \frac{\partial v}{\partial x} & \frac{\partial v}{\partial y} & \frac{\partial v}{\partial z} \\ \frac{\partial w}{\partial x} & \frac{\partial w}{\partial y} & \frac{\partial w}{\partial z} \end{vmatrix}$$

$$= \begin{vmatrix} yz & xz & xy \\ 2x & 2y & 2z \\ 1 & 1 & 1 \end{vmatrix} = 2 \begin{vmatrix} y & x & z \\ yz & xz & xy \end{vmatrix}$$

$$= 2(x-y)(y-z)(z-x) \left[\begin{vmatrix} 1 & 1 & 1 \\ a & b & c \\ bc & ca & ab \end{vmatrix} \right]$$

$$= (a-b)(b-c)(c-a)$$

Now

$$\frac{\partial(u, v, w)}{\partial(x, y, z)} = \frac{1}{\frac{\partial(u, v, w)}{\partial(x, y, z)}}$$

$$= \frac{1}{2(x-y)(y-z)(z-x)}$$

9. (3)

Auxillary equation is

$$m^2 + m = 0$$

$$m(m+1) = 0$$

$$m = 0, m = -1$$

$$C.F = Ae^0 + Be^{-x} = A + Be^{-x}$$

$$\text{If P.I.} = \frac{x^3 + 12x}{3}, \text{ then}$$

$$\text{Solution} = y = A + Be^{-x} + \frac{x^3}{3} + 4x$$

$$\text{then } \frac{dy}{dx} = -Be^{-x} + x^2 + 4$$

$$\frac{d^2y}{dx^2} = Be^{-x} + 2x$$

$$\therefore (D^2 + D)y = \frac{d^2y}{dx^2} + \frac{dy}{dx} = x^2 + 2x + 4$$

\therefore Correct option is (3)

10. (2)

$$x'(t) + 2y(t) = -\sin t \quad \dots (1)$$

$$y'(t) - 2x(t) = \cos t \quad \dots (2)$$

$$x = \cos 2t - \sin 2t - \cos t$$

$$x'(t) = -2\sin 2t - 2\cos 2t + \sin t$$

$$\therefore (1) \Rightarrow$$

$$-2\sin 2t - 2\cos 2t + \sin t + 2y(t) = -\sin t$$

$$\therefore 2y(t) = 2\sin 2t + 2\cos 2t - 2\sin t$$

$$\therefore y(t) = \sin 2t + \cos 2t - \sin t$$

11. (3)

$$f(x) = x^2 + 2bx + 2c^2$$

$$f'(x) = 2x + 2b$$

$$f''(x) = 2$$

$$f'(x) = 0 \Rightarrow 2x + 2b = 0$$

$$\Rightarrow x = -b$$

$$f''(-b) = 2 > 0$$

$$\therefore x = -b \text{ gives minimum}$$

$$\text{Minimum value} = (-b)^2 + 2b(-b) + 2c^2$$

$$= b^2 - 2b^2 + 2c^2$$

$$= -b^2 + 2c^2$$

$$g(x) = -x^2 - 2cx + b^2$$

$$g'(x) = -2x - 2c$$

$$g''(x) = -2$$

$$g'(x) = 0 \Rightarrow -2x - 2c = 0$$

$$\therefore x = -c$$

$$\text{Now } g''(-c) = -2 < 0$$

$$\therefore x = -c \text{ gives maximum}$$

$$\text{Maximum value} = -(-c)^2 - 2c(-c) + b^2$$

$$= -c^2 + 2c^2 + b^2$$

$$= c^2 + b^2$$

$$\text{Minimum value of } f(x) > \text{Maximum value of } g(x)$$

$$\Rightarrow -b^2 + 2c^2 > c^2 + b^2$$

$$\Rightarrow c^2 > 2b^2$$

$$\therefore |c| > \sqrt{2} |b|$$

12. (2)

$$z = a \log \left(\frac{b(y-1)}{1-x} \right)$$

$$p = \frac{\partial z}{\partial x} = \frac{a}{b(y-1)} \times \frac{-b(y-1)}{(1-x)^2} \times -1$$

$$= \frac{a(1-x)}{b(y-1)} \times \frac{b(y-1)}{(1-x)^2} = \frac{a}{(1-x)}$$

$$\Rightarrow (1-x)p = a \quad \dots (1)$$

$$q = \frac{\partial z}{\partial y} = \frac{a}{b(y-1)} \times \frac{b}{(1-x)}$$

$$= \frac{a(1-x)}{b(y-1)} \times \frac{b}{(1-x)} = \frac{a}{y-1}$$

$$\therefore (y-1)q = a \quad \dots (2)$$

From (1) and (2)

$$(1-x)p = (y-1)q$$

$$\Rightarrow p - xp = yq - q$$

$$\therefore p + q = xp + yq$$

13. (2)

$$PI = \frac{e^{x+2y}}{2D^2 - 3DD' + D'^2}$$

$$= \frac{x e^{x+2y}}{(1D - 3D')^2} = \frac{x e^{x+2y}}{4(1-3(2))}$$

$$= \frac{-x e^{x+2y}}{2}$$

14. (4)

Formula :

$$\text{div (grad } f) = \nabla \cdot \nabla f$$

$$= \nabla^2 f$$

$$= \frac{\partial^2 f}{\partial x^2} + \frac{\partial^2 f}{\partial y^2}$$

Now

$$f = \tan^{-1} \left(\frac{y}{x} \right)$$

$$\frac{\partial f}{\partial x} = \frac{1}{1 + \left(\frac{y}{x} \right)^2} \times \frac{-y}{x^2}$$

$$= \frac{x^2}{x^2 + y^2} \times \frac{-y}{x^2} = \frac{-y}{(x^2 + y^2)}$$

$$\frac{\partial^2 f}{\partial x^2} = \frac{(x^2 + y^2)0 + y \cdot 2x}{(x^2 + y^2)^2}$$

$$= \frac{2xy}{(x^2 + y^2)^2}$$

$$\frac{\partial f}{\partial y} = \frac{1}{1 + \left(\frac{y}{x} \right)^2} \cdot \frac{1}{x}$$

$$= \frac{x^2}{x^2 + y^2} \cdot \frac{1}{x} = \frac{x}{x^2 + y^2}$$

$$\begin{aligned}\frac{\partial^2 f}{\partial y^2} &= \frac{(x^2 + y^2) \cdot 0 - x(2y)}{(x^2 + y^2)^2} \\ &= \frac{-2xy}{(x^2 + y^2)^2} \\ \therefore \operatorname{div}(\operatorname{grad} f) &= \nabla^2 f \\ &= \frac{\partial^2 f}{\partial x^2} + \frac{\partial^2 f}{\partial y^2} \\ &= \frac{2xy}{(x^2 + y^2)^2} - \frac{2xy}{(x^2 + y^2)^2} \\ &= 0\end{aligned}$$

15. (3)

$$\begin{aligned}\nabla \cdot \vec{F} &= \left(\frac{\partial}{\partial x} \vec{i} + \frac{\partial}{\partial y} \vec{j} + \frac{\partial}{\partial z} \vec{k} \right) \cdot (ax \vec{i} + by \vec{j} + cz \vec{k}) \\ &= a + b + c\end{aligned}$$

By Gauss divergence theorem

$$\begin{aligned}\iint_S \vec{F} \cdot \hat{n} ds &= \iiint_V \nabla \cdot \vec{F} dv \\ &= \iiint_V (a + b + c) dv \\ &= (a + b + c) \iiint_V dv \\ &= (a + b + c) \text{ volume of the unit sphere} \\ &= (a + b + c) \times \frac{4\pi}{3} (1)^3 \\ &= \frac{4\pi(a + b + c)}{3}\end{aligned}$$

16. (*)

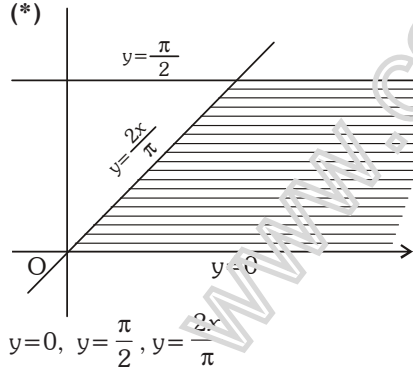

will not form a triangle

\therefore The data given in the problem are not correct.

17. (4)

$$f(z) = u + iv$$

$$\begin{aligned}\Rightarrow f'(z) &= \frac{\partial u}{\partial x} + i \frac{\partial v}{\partial x} \\ &= \frac{\partial u}{\partial x} - i \frac{\partial u}{\partial y}\end{aligned}$$

$$\left[\because \text{By CR equations } \frac{\partial u}{\partial y} = -\frac{\partial v}{\partial x} \right]$$

18. (3)

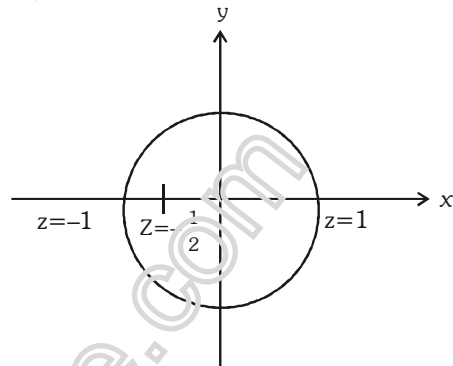

$$\text{Let } f(z) = \frac{3z+4}{2z+1} = \frac{3z+4}{2\left(z+\frac{1}{2}\right)}$$

$\therefore z = -\frac{1}{2}$ is a simple pole

Residue at $z = -\frac{1}{2}$

$$= \lim_{z \rightarrow -\frac{1}{2}} \left(z - \left(-\frac{1}{2} \right) \right) \frac{3z+4}{2\left(z + \frac{1}{2} \right)}$$

$$= \lim_{z \rightarrow -\frac{1}{2}} \frac{3z+4}{2}$$

$$= \frac{3\left(-\frac{1}{2}\right) + 4}{2} = \frac{-3+8}{4} = \frac{5}{4}$$

$$\text{Now } \int_C \frac{3z+4}{2z+1} dz$$

$$= \int_C f(z) dz$$

$$= 2\pi i \text{ (sum of residues of poles within } C)$$

[By Cauchy's Residue Theorem]

$$= 2\pi i \times \frac{5}{4} = \frac{5\pi i}{2}$$

19. (2)

$$\left(\frac{3x}{2}\right)^2 + y^2 = 3^2$$

$$\Rightarrow \frac{x^2}{2^2} + \frac{y^2}{3^2} = 1$$

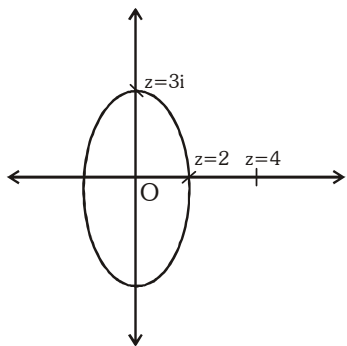

$z = 4$ lies outside of the ellipse

$$\therefore f(z) = \frac{4z^2 + z + 5}{z - 4} \text{ is analytic inside } C$$

$$\therefore \text{By Cauchy's theorem } \int_C f(z) dz = 0$$

$$\Rightarrow \int_C \frac{4z^2 + z + 5}{z - 4} dz = 0$$

20. (4)

To find pole of $\frac{1}{\cos z - \sin z}$ is put $\cos z - \sin z = 0$

$$\Rightarrow \cos z = \sin z$$

$$\Rightarrow \tan z = 1$$

$$\therefore z = \frac{\pi}{4}$$

$$\therefore \text{Pole is } z = \frac{\pi}{4}$$

21. (2)

$$\begin{aligned} L(\sin^2 t) &= L\left(\frac{1 - \cos 2t}{2}\right) \\ &= \frac{1}{2} [L(1) - L(\cos 2t)] \\ &= \frac{1}{2} \left[\frac{1}{s} - \frac{s}{s^2 + 4} \right] \end{aligned}$$

$$L\left(\frac{\sin^2 t}{t}\right) = \frac{1}{2} \int_s^\infty \left[\frac{1}{s} - \frac{s}{s^2 + 4} \right] ds$$

\therefore If $\frac{f(t)}{t}$ has a limit as $t \rightarrow 0$ and $L(f(t)) = F(s)$, then

$$\begin{aligned} L\left(\frac{f(t)}{t}\right) &= \int_s^\infty F(s) ds \\ &= \left[\log s - \frac{1}{2} \log(s^2 + 4) \right]_s^\infty \\ &= \frac{1}{4} \left[\log \frac{s^2}{s^2 + 4} \right]_s^\infty \\ &= \frac{1}{4} \left[0 - \log \frac{s^2}{s^2 + 4} \right] \end{aligned}$$

$$= \frac{-1}{4} \log \frac{s^2}{s^2 + 4}$$

$$L\left(\frac{\sin t}{t}\right) = \frac{-1}{4} \log \frac{s^2}{s^2 + 4}$$

$$\therefore \int_0^\infty e^{-st} \left(\frac{\sin t}{t}\right) dt = \frac{-1}{4} \log \frac{s^2}{s^2 + 4}$$

Put $s=1$

$$\Rightarrow \int_0^\infty e^{-t} \left(\frac{\sin t}{t}\right) dt = \frac{-1}{4} \log \frac{1}{5}$$

$$= \frac{1}{4} \log 5$$

22. (*)

Auxiliary equation is given by

$$m^2 + 9 = 0$$

$$m^2 = -9$$

$$m = \pm 3i$$

$$\text{C.F.} = A \cos 3t + B \sin 3t$$

$$\text{P.I.} = \frac{1}{D^2 + 9} \cos 2t$$

$$= \frac{1}{-4 + 9} \cos 2t = \frac{\cos 2t}{5}$$

$$y(t) = A \cos 3t + B \sin 3t + \frac{\cos 2t}{5}$$

$$y(0)=1 \Rightarrow$$

$$1 = A + \frac{1}{5} \Rightarrow A = 1 - \frac{1}{5} = \frac{4}{5}$$

$$y\left(\frac{\pi}{2}\right)=1 \Rightarrow$$

$$1 = -B - \frac{1}{5} \Rightarrow B + \frac{1}{5} = -1$$

$$B = -1 - \frac{1}{5} = -\frac{6}{5}$$

$$\begin{aligned} \therefore y(t) &= \frac{4}{5} \cos 3t - \frac{6 \sin 3t}{5} + \frac{\cos 2t}{5} \\ &= \frac{1}{5} (4 \cos 3t - 6 \sin 3t + \cos 2t) \end{aligned}$$

23. (1)

Fourier sine transform of $e^{-\frac{ax}{x}}$ is $\tan^{-1}\left(\frac{s}{a}\right)$

25. (4)

Required method – Gauss sieidal method.

26. (3)

$$(0, 1) = (0, 3^0)$$

$$(1, 3) = (1, 3^1)$$

$$(2, 9) = (2, 3^2)$$

$$(4, 81) = (4, 3^4)$$

$$\therefore (3, x) = (3, 3^3)$$

$$\therefore x = 3^3 = 27$$

27. (2)

$$y(0) = 2 = 2^1$$

$$y(1) = 4 = 2^2$$

$$y(2) = 8 = 2^3$$

$$y(4) = 32 = 2^5$$

$$\therefore y(x) = 2^{x+1}$$

$$\begin{aligned} \text{Now } y(3) &= 2^{3+1} = 2^4 \\ &= 16 \\ &\approx 16.5 \end{aligned}$$

If we use any interpolation method we get the value near to 16.5

28. (3)

$$\int_0^{\infty} \int_0^{\infty} kx ye^{-(x^2+y^2)} dx dy = 0$$

$$\text{i.e., } k \int_0^{\infty} ye^{-y^2} dy \int_0^{\infty} xe^{-x^2} dx = 1$$

$$\text{i.e., } \frac{k}{4} = 1$$

$$\therefore k = 4$$

29. (1)

If the two regression lines are perpendicular to each other, then the coefficient of correlation is equal to 0

30. (2)

Moment generating function is

$$\int_0^{\infty} e^{tx} (xe^{-x}) dx = \int_0^{\infty} xe^{x(t-1)} dx$$

$$= \left[x \frac{e^{x(t-1)}}{(t-1)} \right]_0^{\infty} - \frac{1}{(t-1)} \int_0^{\infty} e^{x(t-1)} dx$$

$$= 0 - \frac{1}{t-1} \left(\frac{e^{x(t-1)}}{(t-1)} \right)_0^{\infty}$$

$$= \frac{1}{(t-1)^2}$$